

APPROVAL SHEET

WF12U, WF08U, WF06U, WF04U

$\pm 0.5\%$, $\pm 0.1\%$

TC25

High Precision Thin Film chip resistors

Size 1206, 0805, 0603, 0402

FEATURE

1. SMD metal film resistor
2. High reliability and stability of 0.1% and below per customer request
3. High performance of TCR: 25 ppm/K and below per customer request
4. Low current noise

APPLICATION

- Medical equipment
- Measuring instrument
- Communication device
- Computer
- Printer

DESCRIPTION

The resistors are constructed in a high grade ceramic body (aluminum oxide). Internal metal electrodes are added at each end and connected by a resistive layer that is applied to the top surface of the substrate. The composition of the resistive layer is adjusted to give the approximate resistance required and the value is trimmed to nominated value within tolerance which controlled by laser trimming of this resistive layer.

The resistive layer is covered with a protective coat. Finally, the two external end terminations are added. For environmental soldering issue, the outer layer of these end terminations is a Lead-free solder .

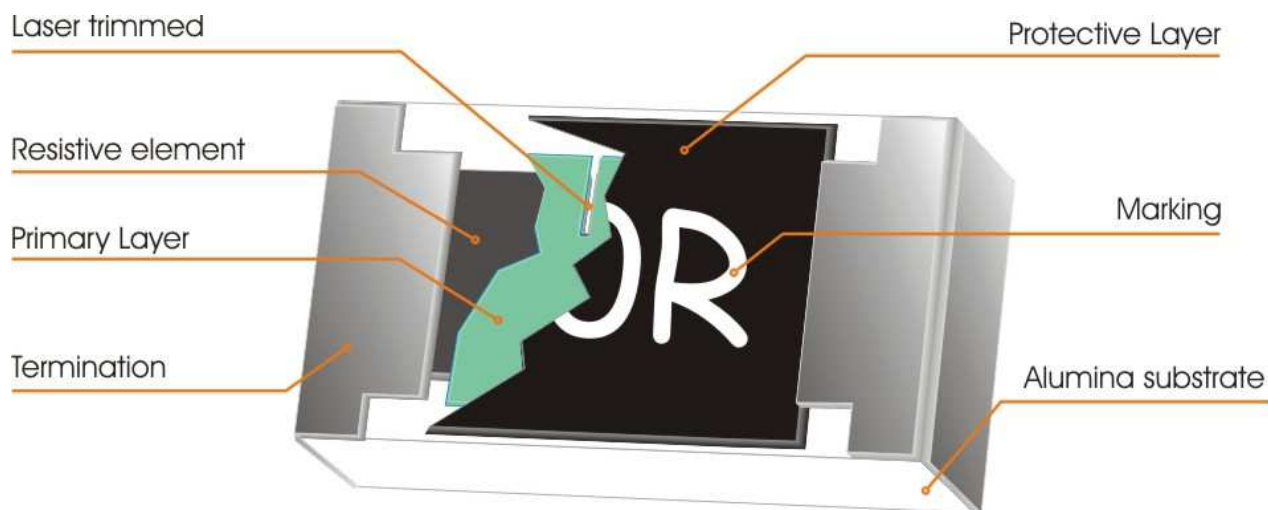

Fig 1. Construction of Chip-R WFxxU

QUICK REFERENCE DATA

Item	General Specification			
Series No.	WF12U	WF08U	WF06U	WF04U
Size code	1206 (3216)	0805 (2012)	0603 (1608)	0402 (1005)
Resistance Tolerance	±0.5%, ±0.1%			
Resistance Range	10Ω ~ 1MΩ (E24 +E96)	10Ω ~ 1MΩ (E24 +E96)	10Ω ~ 330KΩ (E24 +E96)	10Ω ~ 100KΩ (E24 +E96)
TCR (ppm/°C)	+25 ~ -25 ppm/°C			
Max. dissipation at T _{amb} =70°C	1/8W	1/10W	1/16W	1/16W
Max. Operation Voltage (DC or RMS)	150V	100V	50V	25V
Climatic category	55/125/56			

Note :

1. This is the maximum voltage that may be continuously supplied to the resistor element, see “IEC publication 60115-8”
2. Max. Operation Voltage : So called RCWV (Rated Continuous Working Voltage) is determined by

$$RCWV = \sqrt{\text{Rated Power} \times \text{Resistance Value}} \text{ or Max. RCWV listed above, whichever is lower.}$$

Dimensions:

Type	WF12U	WF08U	WF06U	WF04U
L	3.10 ± 0.10	2.00 ± 0.10	1.60 ± 0.10	1.00 ± 0.05
W	1.60 ± 0.10	1.25 ± 0.10	0.80 ± 0.10	0.50 ± 0.05
A	0.45 ± 0.20	0.25 ± 0.20	0.25 ± 0.15	0.20 ± 0.10
B	0.45 ± 0.20	0.40 ± 0.20	0.30 ± 0.15	0.25 ± 0.10
t	0.60 ± 0.15	0.50 ± 0.15	0.45 ± 0.15	0.35 ± 0.05

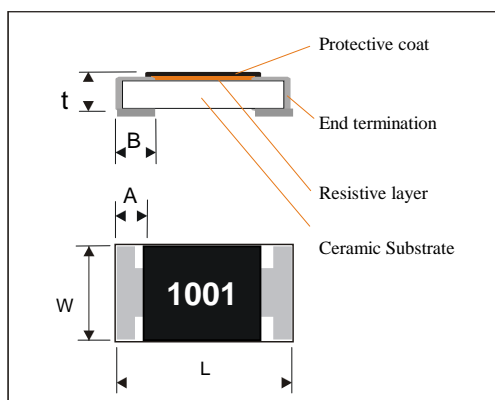

Marking

- **3-digits marking for 0603 size**

WFxxU has same marking rule as WRxx $\pm 1\%$.

- **4-digits marking for 1206, 0805 size**

Each resistor is marked with a four digits code on the protective coating to designate the nominal resistance value. For values below 97Ω the R is used as a digit. For values of 100Ω or greater, the first 3 digits are significant, the fourth digit indicates the number of multiple to follow.

Example

RESISTANCE	10 Ω	12 Ω	100 Ω	6800 Ω	47000 Ω
4-digits marking	10R0	12R0	1000	6801	4702

- **No marking code for 0402 size**

FUNCTIONAL DESCRIPTION

Product characterization

Standard values of nominal resistance are taken from the E96 & E24 series for resistors with a tolerance of $\pm 0.5\%$, $\pm 0.1\%$. The values of the E24/E96 series are in accordance with "IEC publication 60063".

Derating

The power that the resistor can dissipate depends on the operating temperature; see Fig.2

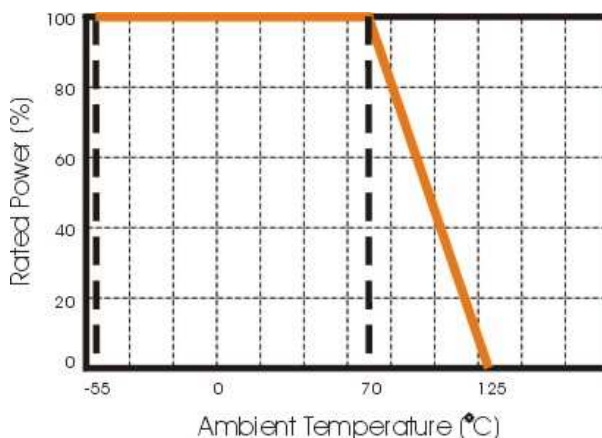

Figure 2. Maximum dissipation in percentage of rated power
As a function of the ambient temperature

MOUNTING

Due to their rectangular shapes and small tolerances, Surface Mountable Resistors are suitable for handling by automatic placement systems.

Chip placement can be on ceramic substrates and printed-circuit boards (PCBs).

Electrical connection to the circuit is by individual soldering condition.

The end terminations guarantee a reliable contact.

SOLDERING CONDITION

The robust construction of chip resistors allows them to be completely immersed in a solder bath of 260°C for 10 seconds. Therefore, it is possible to mount Surface Mount Resistors on one side of a PCB and other discrete components on the reverse (mixed PCBs).

Surface Mount Resistors are tested for solderability at 245°C during 3 seconds within lead-free solder bath. The test condition for no leaching is 260°C for 30 seconds. Typical examples of soldering processes that provide reliable joints without any damage are given in Fig 3.

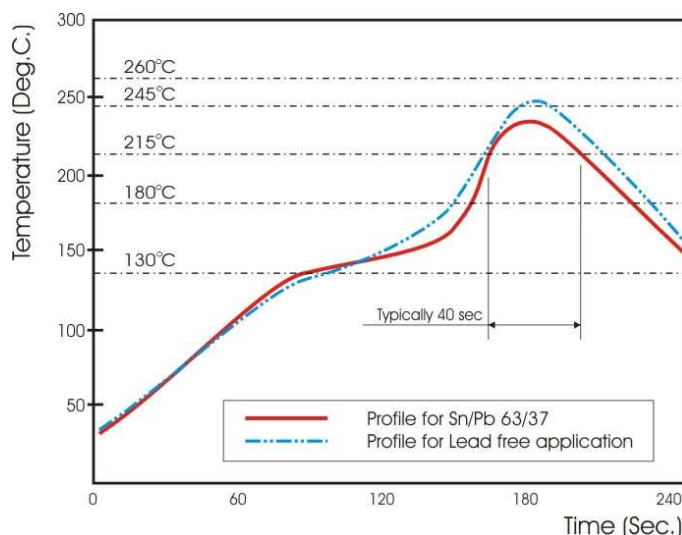

Catalogue numbers

The resistors have a catalogue number starting with .

WF06	U	xxx	D	T
Size code WF12: 1206 WF08: 0805 WF06: 0603 WF04: 0402	Type code U: TCR 25ppm	Resistance code E96 +E24: R is first code followed by 3 significant digits. E24: 39R0=>390 820R =>821 E96: 17R8 =>25X 178R =>25A	Tolerance D : ±0.5% C: ±0.25% B : ±0.1%	Packaging code T : Reeled

1. Reeled tape packaging: 8mm width paper taping.
 5,000pcs/reel for WF12U, WF08U, WF06U;
 10,000pcs/reel for WF04U.

TEST AND REQUIREMENTS(JIS C 5201-1 : 1998)

TEST	PROCEDURE	REQUIREMENT
		Resistor
DC resistance Clause 4.5	DC resistance values measured <10Ω@0.1V, <100Ω@0.3V, <1KΩ@1.0V, <10KΩ@3V, <100KΩ@10V, <1MΩ@25V, <10MΩ@30V	Within the specified tolerance ±0.5%, ±0.1%
Temperature Coefficient of Resistance(T.C.R) Clause 4.8	Natural resistance change per change in degree centigrade. $\frac{R_2 - R_1}{R_1(t_2 - t_1)} \times 10^6 \text{ (ppm/}^\circ\text{C)}$ R ₁ : Resistance at reference temperature R ₂ : Resistance at test temperature t ₁ : 20°C+5°C-1°C	Test temperature -55°C ~ +125°C TCR: ≤±25 ppm/°C
Short time overload (S.T.O.L) Clause 4.13	Permanent resistance change after a 5second application of a voltage 2.5 times RCWV or the maximum overload voltage specified in the above list, whichever is less.	ΔR/R max. ±(0.2%+0.05Ω)
Resistance to soldering heat(R.S.H) IEC 60068-2-58:2004	Un-mounted chips completely immersed for 10±1second in a SAC solder bath at 255°C±5°C	no visible damage Δ R/R max. ±(0.1%+0.05Ω)
Solderability IEC 60068-2-58:2004	Un-mounted chips completely immersed for 3±0.3 second in a SAC solder bath at 245°C±5°C	good tinning (>95% covered) no visible damage
Temperature cycling Clause 4.19	30 minutes at -55°C±3°C, 2~3 minutes at 20°C+5°C-1°C, 30 minutes at +125°C±3°C, 2~3 minutes at 20°C+5°C-1°C, total 5 continuous cycles	no visible damage ΔR/R max. ±(0.1%+0.05Ω)
Load life (endurance) Clause 4.25	1000 +48/-0 hours, loaded with RCWV or Vmax in chamber controller 70±2°C, 1.5 hours on and 0.5 hours off	ΔR/R max. ±(0.5%+0.05Ω)
Load life in Humidity Clause 4.24	1000 +48/-0 hours, loaded with RCWV or Vmax in humidity chamber controller at 40°C±2°C and 90~95% relative humidity, 1.5hours on and 0.5 hours off	ΔR/R max. ±(0.5%+0.05Ω)
Bending strength Clause 4.33	Resistors mounted on a 90mm glass epoxy resin PCB(FR4); bending : 3 mm, once for 10 seconds.	ΔR/R max. ±(0.1%+0.05Ω)
Adhesion Clause 4.32	Pressurizing force: 5N, Test time: 10±1sec.	No remarkable damage or removal of the terminations.
Insulation Resistance JISC5201-1:1998 Clause 4.6	Apply the maximum overload voltage (DC) for 1minute	R ≥ 10GΩ
Dielectric Withstand Voltage JISC5201-1:1998 Clause 4.7	Apply the maximum overload voltage (AC) for 1 minute	No breakdown or flashover

PACKAGING

Paper Tape specifications (unit :mm)

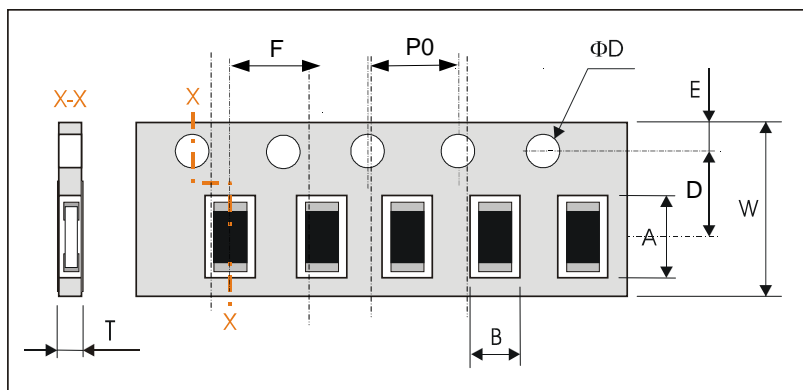

Series No.	A	B	W	D	E
WF12	3.60±0.20	2.00±0.20	8.00±0.30	3.50±0.20	1.75±0.10
WF08	2.40±0.20	1.65±0.20	8.00±0.30	3.50±0.20	1.75±0.10
WF06	1.90±0.20	1.10±0.20	8.00±0.30	3.50±0.20	1.75±0.10
WF04	1.20±0.10	0.7±0.10	8.00±0.20	3.50±0.05	1.75±0.10

Series No.	F	P0	ΦD	T
WF12	4.00±0.10	4.00±0.10	Φ1.50 ^{+0.1} _{-0.0}	Max. 1.0
WF08	4.00±0.10	4.00±0.10	Φ1.50 ^{+0.1} _{-0.0}	Max. 1.0
WF06	4.00±0.10	4.00±0.10	Φ1.50 ^{+0.1} _{-0.0}	0.65±0.05
WF04	2.00±0.10	4.00±0.10	Φ1.50 ^{+0.1} _{-0.0}	0.40±0.05

Reel dimensions

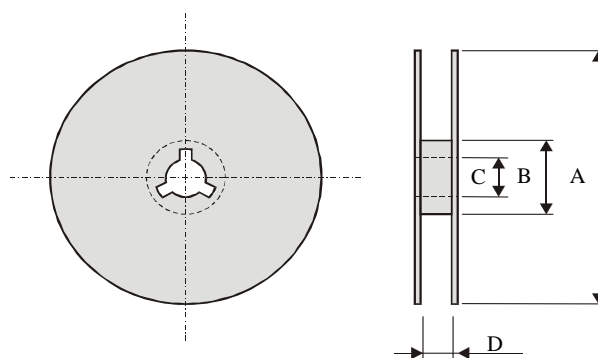

Symbol	A	B	C	D
(unit : mm)	Φ178.0±2.0	Φ60.0±1.0	13.0±0.2	9.0±0.5

Taping quantity

- Chip resistors 5,000 pcs per reel (WF12U, WF08U, WF06U)
- Chip resistors 10,000 pcs per reel (WF04U)