

MULTILAYER CERAMIC CAPACITORS

Ultra Small Series (0201)



1. INTRODUCTION

MLCC consists of a conducting material and electrodes. To manufacture a chip-type SMT and achieve miniaturization, high density and high efficiency, ceramic condensers are used.

0201 MLCC is performed by high precision technology achieve high capacitance in unit size and ensure the stability and reliability of products.

2. FEATURES

- b. High capacitance in unit size.
- c. High precision dimensional tolerances.
- d. Suitable used in high-accuracy automatic mounting machine.

3. APPLICATIONS

- a. Miniature microwave module.
- b. Portable equipments (ex. Mobile phone, PDA).
- c. High frequency circuits.

4. HOW TO ORDER

<u>0201</u>	<u>N</u>	<u>100</u>	<u>J</u>	<u>250</u>	<u>L</u>	<u>I</u>
<u>Size</u>	<u>Dielectric</u>	<u>Capacitance</u>	<u>Tolerance</u>	<u>Rated voltage</u>	<u>Termination</u>	<u>Packaging</u>
Inch (mm) 0201 (0603)	N=NP0 (COG) B=X7R X=X5R	Two significant digits followed by no. of zeros. And R is in place of decimal point. eg.: R47=0.47pF 0R5=0.5pF 1R0=1.0pF 100=10x10 ⁰ =10pF	B=±0.1pF C=±0.25pF D=±0.5pF F=±1% G=±2% J=±5% K=±10% M=±20% Z=-20/+80%	Two significant digits followed by no. of zeros. And R is in place of decimal point. 4R0=4 VDC 6R3=6.3 VDC 100=10 VDC 160=16 VDC 250=25 VDC 500=50 VDC	L=Ag/Ni/Sn (for NP0 dielectric) C=Cu/Ni/Sn (for X7R, X5R & Y5V dielectric)	T=7" reeled

MULTILAYER CERAMIC CAPACITORS

Ultra Small Series (0201)



5. EXTERNAL DIMENSIONS

Size Inch (mm)	L (mm)	W (mm)	T (mm)/Symbol	M _B (mm)
0201 (0603)	0.60±0.03	0.30±0.03	0.30±0.03 L	0.15±0.05

* Reflow soldering only.

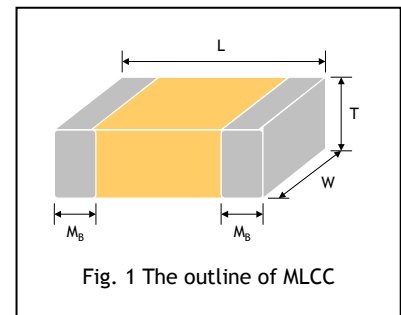

6. GENERAL ELECTRICAL DATA

Size	0201		
Dielectric	NPO	X7R	X5R
Capacitance*	0.5pF to 100pF	100pF to 4700pF	100pF to 0.10μF
Capacitance tolerance**	Cap≤5pF: B (±0.1pF), C (±0.25pF) 5pF<Cap<10pF: C (±0.25pF), D(±0.5pF) Cap≥10pF: F (±1%), G (±2%), J (±5%), K (±10%)	J (±5%), K (±10%), M (±20%)	J (±5%), K (±10%), M (±20%)
Rated voltage (WVDC)	16V, 25V	10V, 16V, 25V, 50V	6.3V, 10V, 16V, 25V, 50V
Tan δ / Q*	Cap<30pF, Q≥400+20C Cap≥30pF, Q≥1000	Ur=50V: ≤3.0% Ur=16V, 25V: ≤3.5% Ur=10V: ≤5.0%	Ur=16V: ≤3.5% Ur=10V: ≤5.0% Ur=6.3V: ≤10%
Insulation resistance at Ur	≥10GΩ	≥10GΩ or RxC≥500ΩxF whichever is less	
Operating temperature	-55 to +125°C		-55 to +85°C
Capacitance change	±30ppm	±15%	
Termination	Ni/Sn (lead-free termination)		

* Measured at 30-70% related humidity.

NPO: Apply 1.0±0.2Vrms, 1.0MHz±10% at the condition of 25°C ambient temperature.

X7R, X5R: Apply 1.0±0.2Vrms, 1.0kHz±10% at the condition of 25°C ambient temperature.

** Preconditioning for Class II MLCC: Perform a heat treatment at 150±10°C for 1 hour, then leave in ambient condition for 24±2 hours before measurement.

MULTILAYER CERAMIC CAPACITORS

Ultra Small Series (0201)



7. CAPACITANCE RANGE

	SIZE	0201	
	DIELECTRIC	NPO	
	RATED VOLTAGE (VDC)	16	25
Capacitance	0.5pF (0R5)		L
	1.0pF (1R0)		L
	1.2pF (1R2)		L
	1.5pF (1R5)		L
	1.8pF (1R8)		L
	2.2pF (2R2)		L
	2.7pF (2R7)		L
	3.0pF (3R0)		L
	3.3pF (3R3)		L
	3.9pF (3R9)		L
	4.0pF (4R0)		L
	4.7pF (4R7)		L
	5.6pF (5R6)		L
	6.8pF (6R8)		L
	8.2pF (8R2)		L
	10pF (100)		L
	12pF (120)		L
	15pF (150)		L
	18pF (180)		L
	22pF (220)		L
	27pF (270)		L
	33pF (330)		L
	39pF (390)		L
	47pF (470)		L
	56pF (560)	L	L
	68pF (680)	L	L
	82pF (820)	L	L
	100pF (101)	L	L

	SIZE	0201									
	DIELECTRIC	X7R					X5R				
	RATED VOLTAGE (VDC)	10V	16V	25V	50V	6.3V	10V	16	25	50	
Capacitance	100pF (101)		L	L	L			L	L	L	
	120pF (121)		L	L	L			L	L	L	
	150pF (151)		L	L	L			L	L	L	
	180pF (181)		L	L	L			L	L	L	
	220pF (221)		L	L	L			L	L	L	
	270pF (271)		L	L	L			L	L	L	
	330pF (331)		L	L	L			L	L	L	
	390pF (391)		L	L	L			L	L	L	
	470pF (471)		L	L	L			L	L	L	
	560pF (561)		L	L	L			L	L	L	
	680pF (681)		L	L	L			L	L	L	
	820pF (821)		L	L	L			L	L	L	
	1,000pF (102)		L	L	L			L	L	L	
	1,500pF (152)	L	L				L	L			
	2,200pF (222)	L	L				L	L			
	3,300pF (332)	L	L				L	L			
	4,700pF (472)	L	L				L	L			
	6,800pF (682)	L					L				
	0.010μF (103)	L					L				
	0.015μF (153)						L				
	0.022μF (223)						L				
	0.033μF (333)						L				
	0.047μF (473)						L				
	0.068μF (683)						L				
	0.10μF (104)						L				

1. The letter in cell is expressed the symbol of product thickness.

8. PACKAGING DIMENSION AND QUANTITY

Size	Thickness (mm)/Symbol		Paper tape	
			7" reel	13" reel
0201 (0603)	0.30±0.03	L	15K	-

Unit: pieces

MULTILAYER CERAMIC CAPACITORS

Ultra Small Series (0201)



9. APPENDIXES

▣ Tape & reel dimensions

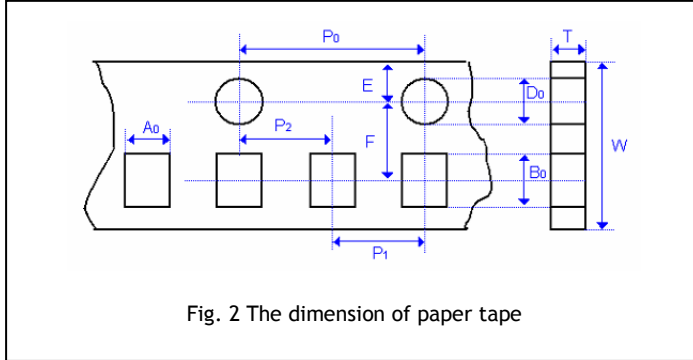

Fig. 2 The dimension of paper tape

Size	0201
Thickness	L
A ₀	0.37±0.03
B ₀	0.67±0.03
T	0.42±0.03
K ₀	-
W	8.00±0.10
P ₀	4.00±0.10
10xP ₀	40.0±0.10
P ₁	2.00±0.05
P ₂	2.00±0.05
D ₀	1.55±0.05
D ₁	-
E	1.75±0.05
F	3.50±0.05

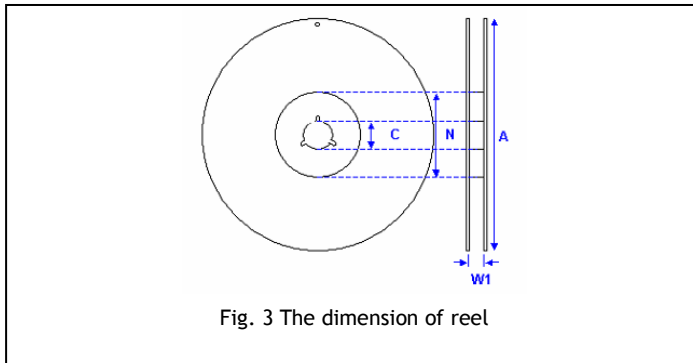
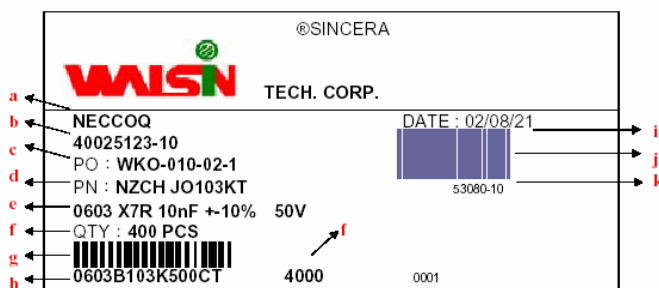

Fig. 3 The dimension of reel

Size	0201	
Reel size	7"	13"
C	13.0+0.5/-0.2	13.0+0.5/-0.2
W ₁	8.4+1.5/-0	8.4+1.5/-0
A	178.0±0.10	330.0±1.0
N	60.5±1.0	100±1.0

▣ Description of customer label



- Customer name
- WTC order series and item number
- Customer P/O
- Customer P/N
- Description of product
- Quantity
- Bar code including quantity & WTC P/N or customer
- WTC P/N
- Shipping date
- Order bar code including series and item numbers
- Serial number of label

MULTILAYER CERAMIC CAPACITORS

Ultra Small Series (0201)



Constructions

No.	Name	NPO	X7R, X5R, Y5V
①	Ceramic material	BaTiO ₃ based	
②	Inner electrode	AgPd alloy	Ni
③	Termination	Inner layer	Ag Cu
④		Middle layer	Ni
⑤		Outer layer	Sn (Matt)

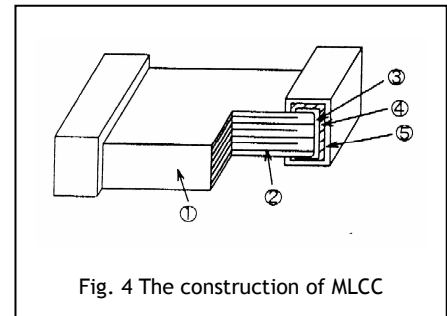

Fig. 4 The construction of MLCC

Storage and handling conditions

- (1) To store products at 5 to 40°C ambient temperature and 20 to 70% related humidity conditions.
- (2) The product is recommended to be used within one year after shipment. Check solderability in case of shelf life extension is needed.

Cautions:

- a. Don't store products in a corrosive environment such as sulfide, chloride gas, or acid. It may cause oxidation of electrode, which easily be resulted in poor soldering.
- b. To store products on the shelf and avoid exposure to moisture.
- c. Don't expose products to excessive shock, vibration, direct sunlight and so on.

Recommended soldering conditions

The lead-free termination MLCCs are not only to be used on SMT against lead-free solder paste, but also suitable against lead-containing solder paste. If the optimized solder joint is requested, increasing soldering time, temperature and concentration of N₂ within oven are recommended.

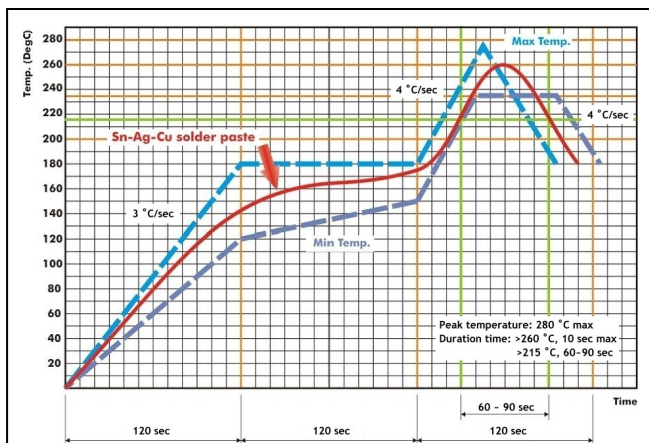

Fig. 5 Recommended IR reflow soldering profile for SMT process with SnAgCu series solder paste.

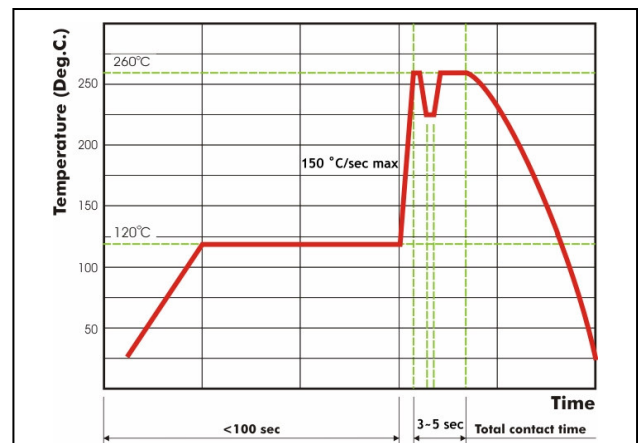

Fig. 6 Recommended wave soldering profile for SMT process with SnAgCu series solder.